



## OPERATION OF THE MULTILIFT

### 1.0 OPERATING THE MULTILIFT

Insert the key and turn it to the operating position on any call/send control (FIGURE 1.0). The key is in the operating position when it cannot be pulled out. **Always take the key out when the unit is not in operation.** Apply constant pressure on the appropriate button to call the platform to the landing. The Multilift will not move if one of the doors or one of the gates is open.

FIGURE 1.0 (The call station on your unit may differ from the one shown)

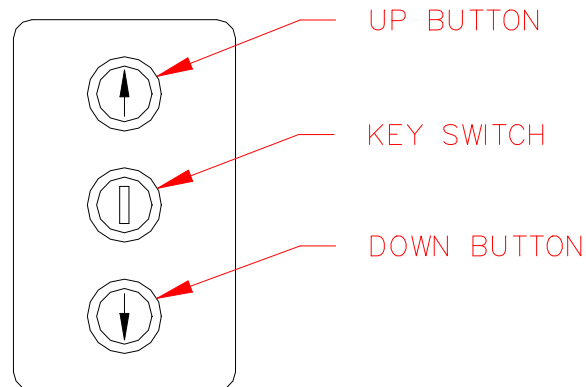

### 2.0 OPENING THE DOOR OR THE GATES (OPTIONAL EQUIPMENT)

#### 2.1 Mechanical locks

The door or the gate will unlock automatically when the platform reaches the landing.

#### 2.2 Electric strikes

The door or the gate will unlock automatically for a few seconds when the platform reaches the landing. If you need to reopen the door after the delay is over, turn the key on and press the call button once again. This will unlock the door or the gate once again.

### 3.0 CAB CONTROLS

FIGURE 2.0

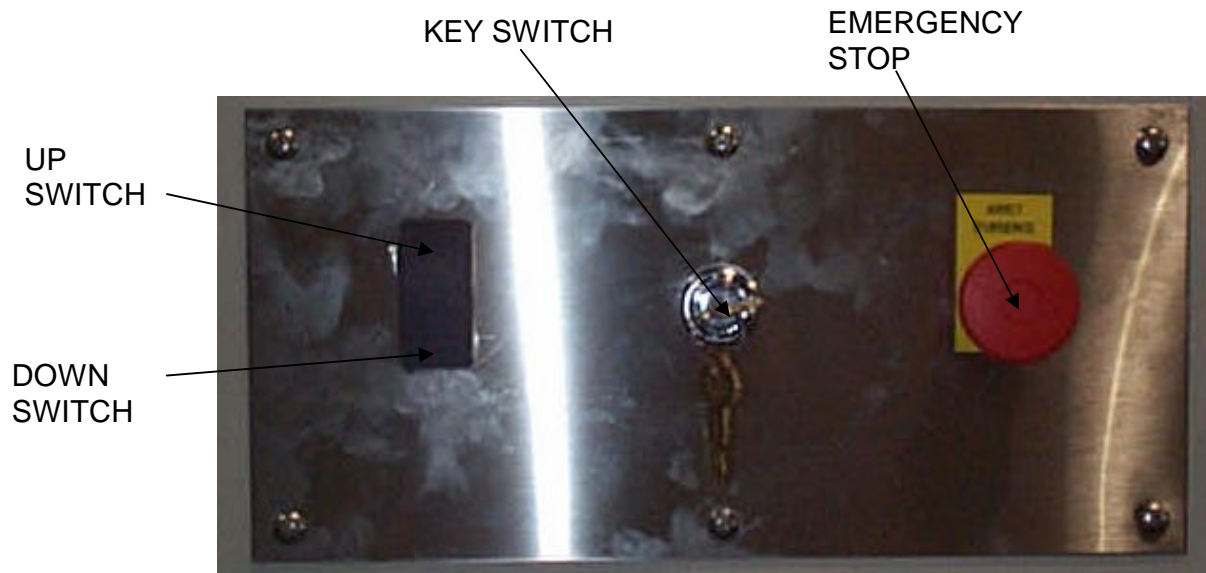

- Key switch : Needs to be on to activate the operating buttons.
- Up switch : Will move the platform in the up direction.
- Down switch : Will move the platform in the down direction.
- Emergency stop : Will stop the platform instantly. Overrides the call stations.

### 4.0 SAFETY DEVICES

- Underpan sensor : Located under the platform, it will stop it if something is hit during the down travel.
- Door contacts : Will prevent the platform from moving with any of the doors or the gate opened.

## 5.0 **EMERGENCY DOOR OPENING**

### 5.1 GAL LOCK

The door or the gate can be opened manually using a special key into the round pin on the front of the lock (see figure 3.0) **This key is for emergency use only. It should always be kept in a safe place and used by trained personnel only.**

### 5.2 DOOR STRIKE ON DOORS PROVIDED BY SAVARIA

The door or the gate can be opened manually using a ¼ inch allen key through the front hole in the door (see figure 4.0) **This key is for emergency use only. It should always be kept in a safe place and used by trained personnel only.**

### 5.3 DOOR STRIKE ON DOORS PROVIDED BY OTHERS

See your dealer for appropriate instructions.

FIGURE 3.0

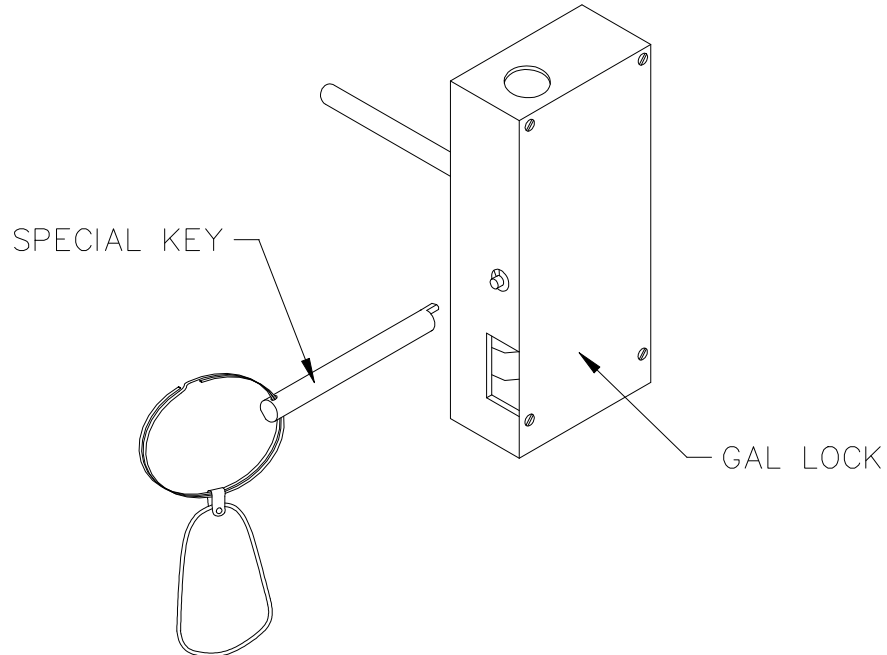
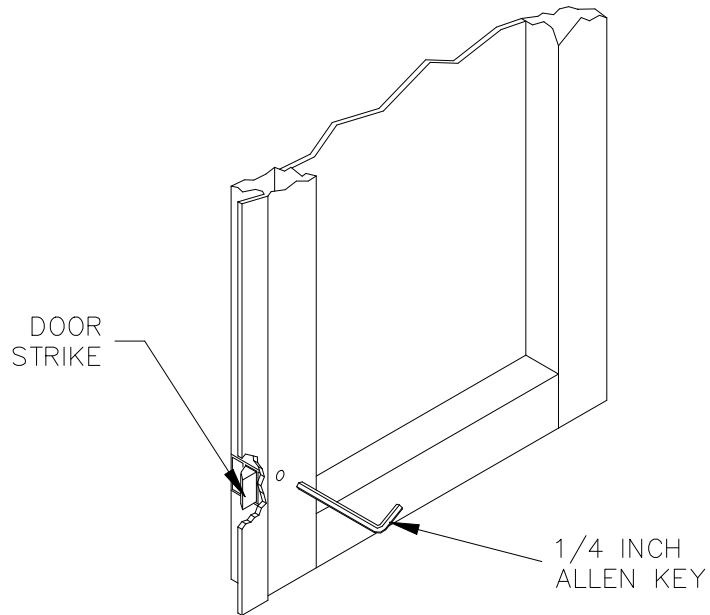

FIGURE 4.0



**6.0 MANUAL LOWERING DEVICE**

6.1 In case of emergency situation, it is possible to lower the platform manually. Take off the cap and use the hand crank (see figure 5.0). Turn it to move the unit to the desired position to reach the landing. Always take the hand crank out when the unit is in operation.

FIGURE 5.0



FIGURE 6.0

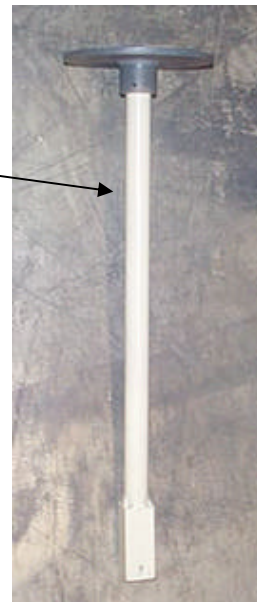

## **7.0 MAINTENANCE**

EVERY TWO MONTHS :

- Verify general operation of the MULTILIFT.
- Verify the operation of the safety devices :
  - Underpan safety switches
  - Door contact
  - Door lock
  - Emergency stop

The lift should never run when those devices are activated or when the door or the gate is not closed.

These verifications can be made by the owner.

EVERY SIX MONTHS:

Verify

- General operation of the lift.
  - Operation of the underpan sensor
  - Operation of the emergency stop
  - Operation of the door and gate lock contacts. The lift should not run unless the door or gate is closed and locked.
- 
- Verify safety components
    - Operation and alignment of the up final limit switch (activate by hand).
    - Operation of the backup nut switch
    - Operation of the load switch. Lower the platform to the ground using the hand crank in order to release the load on the main nut. The lift should not run up until you restore the load on the main nut by moving the platform up with the hand crank.
    - Up relays : verify that any of the two up relays are not stuck in the activated position. Use a multimeter to verify that every N.O. contact is open when the relays are not activated.
  
  - Verify every fastening device for looseness

- Verify general components
  - Rollers
  - Battery fluid level (optional system)
  
- Lubricate
  - Acme screw.
  - Upper bearing.

Recommended lubricant : High quality wheel bearing grease.

## 8.0 TROUBLESHOOTING

- Platform goes up but does not come down :
  - Verify the underpan sensor. Pull down on it to ensure the pan is not stuck in the activated position.
  
- Platform goes down but does not go up :
  - Verify the charge and fluid level of the battery (battery operation only).
  
- Platform does not move :
  - Verify if the key is on.
  - Verify if the doors are closed.
  - Verify if the emergency stop is pushed in. It should be pulled out.
  - If the platform is at the top landing, verify the underpan sensor as explained above.
  - Verify the power supply (breaker, cord, etc.)

## **Savaria Concord Lifts, Inc.**

### **Manufacturer's Limited Product Warranty**

Term of warranty – this warranty is valid for a period of 36 months from the date that the product shipped from our factory. Purchase price for product must be paid in full for manufacturer to release parts under this warranty.

Coverage – this warranty applies to the repair or replacement, at Manufacturer's option, of parts that fail due to defective material or workmanship. Manufacturer may, at its option, provide factory reconditioned parts. This warranty is provided to the Authorized Savaria Concord Dealer on behalf of the final purchaser of the product and is not transferable. The Manufacturer's warranty does not cover labor charges for the removal, repair or replacement of warranty parts but such costs may be covered for a period of time by Authorized Dealer's warranty, which is provided to purchaser separately.

#### **Conditions:**

- 1) This warranty only applies to products installed and maintained by a Savaria Concord Elevator Authorized Dealer in conformance with all applicable local and national codes.
- 2) The warranty is void if regular inspection and maintenance of product is not being carried out by an Authorized Savaria Concord Dealer in accordance with the recommendations contained in the Owner's Manual. It is the Owner's responsibility to keep records of all such service.
- 3) This warranty does not apply to the following:
  - 1) Consumable items which include: light bulbs, batteries, oil seals, mechanical switches, guide shoe inserts, drive belts, hydraulic fluids, greases, oils etc.
  - 2) Structural or cosmetic components that are subject to normal wear and tear, external forces and/or misuse. This includes metal panels, glass, plexiglass, gates, doors, buttons, switches, upholstery, trim etc
  - 3) Items that require periodic assessment, maintenance and/or replacement. This includes paint, caulking, weather seals, etc
  - 4) Malfunction or damage to product caused by accident, misuse, abuse or vandalism, lack of proper maintenance, improper installation or placement of product, neglect, improper adjustment, modification or alteration, structural condition of building or hoistway, overloading, failure to follow operating instructions or acts of God.

#### **Standard Procedures:**

Required warranty parts will be shipped at Savaria Concord's expense by UPS ground. Expedited or air shipment of parts is available at Dealer's request and expense. Some parts covered under this warranty may be commercially available from a source close to the job site and Savaria Concord will reimburse Dealer for cost to purchase these items provided that approval is obtained from Savaria Concord's Technical Support Department in advance.

#### **Disclaimers:**

*Savaria Concord Lifts, Inc. disclaims liability for any personal injury or property damage resulting from the operation of a product that has been modified from the original Savaria Concord design. No person or company is authorized to change the design of this product without written authorization by Savaria Concord.*

*Savaria Concord's obligation under this warranty is exclusively limited to the repair or exchange of parts that fail within the applicable warranty period.*

*Savaria Concord assumes no responsibility for expenses or damages, including incidental or consequential damages. Some states and/or provinces do not allow the exclusion or limitation of incidental or consequential damages so the above limitation may not apply to you.*

---

*This Warranty supercedes all other published warranties in Owner's and Installation Manuals and applies to all Savaria Concord Lifts, Inc. shipped after November 14, 2005  
Part Number 000599 Rev 11/05*